

**A Brief History of Pullout Testing: With Particular Reference to Canada**

**A Personal Journey**

**By John A. Bickley, P.Eng.**

**Synopsis:** From the 1930's to the 1970's a number of researchers in Russia, the US and Canada worked on the development of a reliable pullout test. In Denmark Kierkegaard-Hansen's research first established pullout insert dimensions that resulted in a straight line relationship between the pullout force and compressive strength. This led to the development by Germann-Petersen of a portable tester suitable for site use

Subsequently the procedure proved effective in assuring safe form removal times at early ages and in the acceleration of construction schedules. Experience worldwide over the last 30 years has established the usefulness of the test and it has been standardised in many countries.

**Keywords:** pullout, compressive strength, accelerated construction, safety.

International Conference on Non-Destructive Testing, ACI, Seville, Spain, Oct 15th 09

John A. Bickley is a Registered Engineer in the Province of Ontario; A Fellow of ACI, The Institution of Civil Engineers (UK) and The Canadian Society of Civil Engineering. He is the recipient of the ACI Concrete Practice and Delmar Bloem Awards and has served on a number of ACI Committees.

### Introduction

From the 1930's to the 1970's a number of researchers worked on the development of the pullout test as an in-situ method of determining the strength of concrete in a structure. Research in Russia in the years 1934-1938 by Volf, Charckov and Gershberg was reported in 1938 by Skramtajev. In the 1960's and 1970's Richards in the US and Malhotra in Canada carried out experiments with prototype equipment and initiated the drafting of an ASTM test procedure. During this period Kierkegaard-Hansen in Denmark established the relative dimensions of the pullout and pullout test equipment that resulted in a straight line correlation between pullout force and compressive strength.

A field research programme funded by the National Research Council of Canada showed that the pullout test was an accurate way of determining the compressive strength of concrete in-situ. However the 3 inch diameter pullout used by Richards and Malhotra resulted in large, cumbersome test equipment impractical for site use. In Denmark, using the relationships determined by Kierkegaard-Hansen, Germann-Petersen designed a portable pullout tester that fitted into a briefcase and was eminently suitable for site use.

By the late 1970's rapid construction of reinforced concrete high-rise buildings in Ontario was facilitated by the use of flying forms enabling the casting of two or more floors per week. This led to the need to remove support from flat slabs at early ages. A rapid, reliable in-situ test was needed to determine when forms could be removed safely. The pullout test proved to be the answer. Since accelerated construction could be shown to result in significant financial benefits, the flying form-pullout test combination was adopted on many sites. This paper mainly discusses the use of pullout testing in Ontario, Canada.

### Safety

One of the potentially dangerous operations during construction is the removal of formwork from suspended slabs. This has been dealt with in the past by mandating a conservative waiting time before form removal or by making various tests to estimate the compressive strength in-situ of the concrete. The most common test procedure in the past has been the use of field-cured test specimens and this approach is used in some current specifications. Field-cured test cylinders are supposed to be cured on the structure close to and in such a way that they represent the strength of the concrete in the structure. In practice it is not easy to ensure that the curing history of the field-cured test specimens is similar enough to the concrete in the structure for this approach to be reliable. This approach is also subject to abuse. As one site superintendent put it many years ago when challenged about his winter practice of curing these specimens in his heated site office "If I leave them on the structure the test results will be low and the Engineer will not let me remove the forms!" An example of this approach was witnessed as recently as a few years ago.

It is also difficult to persuade owners and contractors to spend more money for a better guarantee of safety. This recognition led to an approach to the marketing of pullout testing that is described later.

In 1970, a 16 storey apartment building in Boston collapsed during construction. The concrete in the top floor slab froze shortly after placement and remained frozen all winter until a thaw in February when the concrete in the penthouse was placed. The 28-day strengths of the standard-cured test cylinders met specified strength requirements but the in-situ compressive strength was only half the specified 28-day strength several months after placing. In-situ tests on the thawed slab would have prevented this tragedy in which four construction workers died.



A much greater tragedy occurred at a cooling tower site at Willow Run, West Virginia where form removal at one day resulted in 51 deaths. The contractor involved subsequently became a very conscientious devotee of pullout testing.

The potential for collapse and the advent of a portable pullout tester was the perfect confluence of a problem and its solution. When he was President of ACI, Bob Philleo wrote an editorial to the effect that no structure had ever collapsed where the concrete strength had been determined in-situ.

#### Enter Lok-Test

It may offend those purists who consider it verboten to use a product name in a technical paper but the rationale is that this name is to pullout testing as Kleenex is to tissue and Xerox is to copying.

The equipment is well designed and made and is simple to use. A set of 10 pullouts can be tested and the strength of a 100 m<sup>3</sup> (130 yd<sup>3</sup>) slab cleared for form removal in 20 minutes. Typically the forming personnel on a site become knowledgeable in the significance of dial readings and will watch the dial on the tester. After seeing a few results they will start loosening bolts knowing that the test result will be acceptable and the forms can be flown for the next slab.

It has been suggested that the need to place the inserts before the concrete is placed is somehow a defect in the system that compromises the validity of the test results. In practice it would be next to impossible to affect the test results. The practicalities of placing concrete do not and cannot include some direction to achieve an unnatural result. Ten inserts placed in different locations in a 100 m<sup>3</sup> (130 yd<sup>3</sup>) placement really are representative of that concrete. What is important is that a significant number of test results can be obtained quickly and economically and allow the minimum strength of a placement to be calculated with a high degree of confidence (Bickley, 1982). This is the biggest advantage and the most significant difference between pullout testing and other test methods.

As with all new test procedures legitimacy depends on the writing and publication of National standards. Without these it is unlikely that a new test method will be adopted by specification writers. Initially action was taken on the ASTM C-9 Committee on Concrete and Concrete Aggregates and was the responsibility of Subcommittee C09.64 on Nondestructive and In-Place Testing. With the advent of Lok-Test, this subcommittee was energised to finish drafting a standard and ASTM C-900-78T was published in 1978. Since then standardisation has taken place in Denmark, Sweden, Norway, Finland, Britain and Germany and also in the European Standard applying to all EEC Countries.

The following figure shows the essential dimensions of the system and the testing mode.

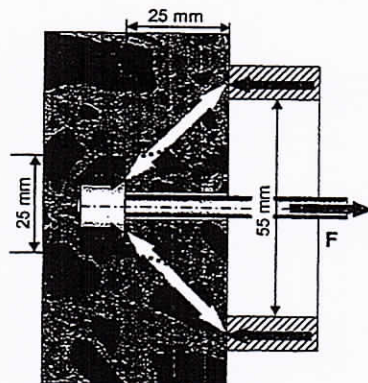

## Canadian Standard CSA A23

Canadian Standards Association (CSA) Standard A23.1 "Concrete Materials and Methods of Concrete Construction" is the primary standard for concrete construction in Canada. At the time of writing this paper the 2004 edition was in effect.

Unless otherwise specified by the Owner Clause 4.4.6.2 titled "In-place strength" requires tests on cores or pullout tests to be made when the in-place strength is to be determined to:

- a) Remove forms or apply prestressing or post-tensioning;
- b) Terminate curing;
- c) Remove reshores.

Since coring and the testing of cores would generally be impractical the preference is clearly for pullout testing.

CSA A23.2 "Methods of Test and Standard Practices for Concrete" mandates the testing of concrete and concrete materials. Test procedure A23.2-15C "Evaluation of concrete strength in-place using the pullout test" generally follows ASTM C900 and also provides guidance with regard to field practice in the use of this procedure. The requirements of this standard are met by the Lok-test system.

### Concrete Optimisation

As stated earlier, it is difficult to sell increased costs for safety. Concrete Optimisation is a term adopted for the cost analysis of the potential benefits of accelerating construction on a site (Bickley 1982, 1984). By analysing the costs and savings of accelerating construction the Owner is provided with a helpful decision making tool. The following is a simplified example of an analysis that applied to an actual project in the 1980's (all amounts are in Canadian dollars):

1. Rationale
  - a) For each month that the construction schedule can be shortened, reductions in interest and overhead, and acceleration of rental income the saving is \$ 233,000.
  - b) Acceleration of the cast-in-place concreting programme would make an overall acceleration possible.
  - c) Concrete mixtures and testing methods that make an accelerated programme possible are available.
  - d) It is assumed that there will be competent and appropriate input into the specification and the quality control of concrete.
2. Technical Proposal
  - a) Allow floor form removal at 75% of  $f'_c$ .
  - b) Provide a suite of concrete mixtures that will reach form removal strength at early ages down to 24 hours after casting. (The reason more than one mix is needed for maximum savings is that casting on Fridays when the next work day will be Monday limits the earliest form removal to 3 days)
  - c) Accelerate form removal and reshoring to match the fastest practical schedule
  - d) Design concrete mixtures for all vertical elements to meet specified strength requirements at 91 days. ( This is an additional saving possible by substituting a later acceptance age and incorporating Supplementary Cementing Materials (SCMs) into the concrete mixes)
3. Actions required for Acceleration
  - a) Documents for concrete supply, forming and placing need amendments.
  - b) The forming and placing contractor is a key player and needs to be motivated.
  - c) Appropriate Quality Control of concrete production is essential.
4. Table 1 Costs to Owner



	Sub-structure	Superstructure
Additional cost of accelerated concrete mixes	NA	\$ 151,606
Saving on concrete meeting strength at 91-days	\$ 39,000	\$ 37,500
Saving on winter heating costs	NA	NA
Net additional cost of concrete	\$ 39,000	\$ 114,106
Net additional cost of project concrete	\$ 75,106	
Cost of in-situ testing with resident inspector	NA	\$ 38,600
Cost of standard testing	\$ 14,000	\$ 15,000
Net additional cost of in-situ resident inspector	NA	\$ 23,600
Net additional cost to Owner	\$ 98,706	

5. Table 2 Savings to Owner

Reduction in financing costs:	
1 month acceleration	\$ 187,500- \$ 190,000 say \$ 188,000
2 months acceleration	\$ 376,000
Earlier rental per month	\$ 25,000
Owners overhead per month	\$ 20,000
Credits from contractor	Not considered on this project
Saving to Owner: one month acceleration	\$ 233,000
Net saving to Owner	\$ 137,894

A summary of savings on a number of projects (Bickley and Hindo 1994) is shown in Table 3. On some projects the Owner did not state the amount of savings but in all the projects listed acceleration and the use of pullout testing was accepted by the Owners as the most economically advantageous solution. The success of this approach depends on having the Owner's authority fully behind this approach and key trades like the formwork sub-contractor motivated. Since acceleration generally results in the more efficient use of flying forms there is an economic benefit to that sub-contractor. On one contract the formwork sub-contractor offered the Owner a substantial cost reduction if allowed to accelerate construction.

Table 3 Savings to Owners

	20 Storey Office Building	15 Storey Utility Headquarters	30 Storey Office Building	Twin Apartment Towers, 30 and 31 Storeys	14 Storey Office Building <sup>5</sup>	3 Storey Computer Centre	9 Storey Condominiums
Savings	(All Numbers are \$/1000)						
Interest	600	1750	188	NC	NC	533	43
Earlier Rental	200	NC	25	NC	NC	466	40
Formwork	120	25 <sup>4</sup>	NC	75	NC	NC	NC
Reshoring	NC	NC	NC	NC	NC	NC	NC
Winter Heating	NC	NC	114	(0.3/pour/day)	NC	NC	NC
f <sub>c</sub> at 91 days	NA	50	38	62	23	NA	NA
Design	120	NA	NA	NA	NA	NA	NA
Overhead	NC	NC	20	NC	NC	NC	NC
Sub-Total	1040	1825	385	137	NC	999	83
Costs							
Concrete	20 <sup>1</sup>	320	152	56	93	20	0
Testing	15 <sup>2</sup>	38	24	10	14	10	4
Sub-total	35	358	176	66	107	30	4

Net Saving	1005 <sup>3</sup>	1467	209	71	NC	969	79
------------	-------------------	------	-----	----	----	-----	----

Notes: NC: Not Calculated, NA: Not applicable, 1. 0.04\$/sq.ft. (0.43\$/m<sup>2</sup>). 2. 0.03\$/sq.ft. (0.35\$/m<sup>2</sup>) 3. 5% of total cost, 4. Refund from forming contractor, 5, Project started behind schedule. Time made up by acceleration.

### Acceptance of Concrete by In-place tests

#### Normal Practice

Traditionally in most countries the acceptance of concrete has been based on tests made 28 days after the concrete is delivered and placed in the structure (As Philleo once pointed out in an editorial entitled "Lunatics at Babel", 28 days is a lunar month). These "standard-cured test specimens" are cured in a laboratory in specified moisture and temperature conditions. These conditions may bear no relation to the environment to which the concrete in the structure is subjected.

#### Demonstration projects

On two projects in Toronto permission was obtained from the City of Toronto Building Department to accept concrete on the basis of pullout tests and the usual requirement for concrete cylinder testing was waived.

The projects were Trinity Square, the new headquarters for Bell Canada and the College Park Phase 2, 30 storey office building (Bickley 1984).

Standard-cured test cylinders were made and tested because the intent was to compare the reliability of the two approaches.

#### Project Specifications

Relevant extracts are as follow:

*"Issue reports of in-place testing to Structural Engineer, Resident Engineer and Construction Manager immediately after tests are made and checked. Keep file on site.*

*Concrete tested with pullouts: Until correlation between 28-day pullout tests and concrete cylinders tests is satisfactory to the Engineer, make 2 cylinders per 100 cubic meters or less of each pour for testing at 28 days.*

*Where in-place testing is required install at least 15 pullout inserts per 100 m<sup>3</sup> of concrete. For pours in excess of 100 m<sup>3</sup> provide at least an additional insert per 20m<sup>3</sup>. Install 2 additional pullout inserts per pour for testing at 28 days.*

*In the substructure install inserts on the top of slabs at random locations agreed by the Engineer. In the superstructure direct the installation of inserts at random locations agreed by the Engineer.*

*Test inserts just prior to the time it is proposed to remove forms. Generally at least 10 tests will be made. If the first 5 tests indicate the concrete is below form removal strength discontinue testing and reschedule. If a set of 10 tests indicates results marginally below the required values recommend further tests or additional curing.*

*After checking report the results on the approved form as provided in the terms of reference.*

*Where necessary to check exposed areas make additional tests either using additional inserts or maturity meters.*



Test 2 inserts at 28 days.

During cold weather concreting make temperature checks within the heated or insulated areas and record.

#### Summary of Test Results

Specified 28-day compressive strength was 30 MPa (4350 psi)

Table 4 Tests for Form Removal

	Trinity Square		College Park
	Inserts placed		
	Top of slab	Bottom of slab	Bottom of slab
Age at test: days	3-7	2-7	3-21
No of sets of tests	24	177	102
No of inserts in set of tests <sup>1</sup>	6-14	2-14	3-23
Mean strength all tests: MPa (psi)	26.2 (3800)	27.8 (4030)	25.9 (3760)
Mean standard deviation of all tests: MPa (psi)	3.5 (508)	2.4 (348)	2.8 (406)

1. Typically 10 were tested

Table 5 Tests at Later Ages

	Trinity Square	College Park
Age at test: days	9-87	26-63
No of sets of tests	127	68
No of inserts in a set of tests	2	1-5
Mean strength of all tests: MPa (psi)	35.6 (5160)	37.6 (5450)
Mean standard deviation of all tests: MPa (psi)	4.1 (595)	4.2 (609)
Lowest test result: MPa (psi)	30.9 (4480)	30.7 (4450)

Table 6 Tests on Standard-cured Cylinders

	Trinity Square	College Park
No of tests	132	79
Mean strength: MPa (psi)	39.5 (5730)	39.1 (5670)
Standard deviation: MPa (psi)	4.2 (609)	4.2 (609)

#### Confirmation Procedure

The average strength, standard deviation and indicated minimum strength of each set of test results was calculated by the site technician who then phoned the individual test results to head office where an authorised person checked the calculations and confirmed that they were correct. The technician then had the Structural Engineer's site representative sign approval of the test result and the contractor could then remove the floor forms.

#### Scotia Plaza

This 68 storey office building in the heart of downtown Toronto was the first major use of 70 MPa concrete and silica fume in Toronto (Ryell and Bickley 1987).

A self-climbing form system used the latest vertical elements cast as support. A compressive strength of 10 MPa (1450 psi) was specified for these vertical elements providing support. It was not practical to install more than two inserts in a column so maturity meters were used to predict when the concrete had reached the required strength so that confirmation by the physical pullout tests was virtually assured.

The target productivity was the casting of a floor every 3 days and this was achieved by the early removal of vertical forms, on occasions as early as 11 hours after casting. The testing procedures used provided confidence in the safety of what was a daring approach to fast construction.

#### **Potential for Use with Performance-Based Specifications**

There is an increasing interest in North America in recent years in the use of performance specifications, a subject that has been of wide interest prior to this in Europe, South Africa Australia and New Zealand (Bickley et al 2006 and 2008).

With the trend to performance specifications the basic determination of the acceptability of the strength of concrete as delivered to site will routinely become the responsibility of the concrete supplier.

Perhaps the most contentious aspect of the specification of concrete on the basis of performance is verification by owners of the in-place quality and thus the durability of concrete in the structure. To meet this need pullout tests could be made at early ages and correlated with the strength/age properties of the approved concrete mixture to confirm that the concrete in place is of the intended durability as well as strength. Additional confidence could be achieved by supplementing the pullout data with the maturity of the concrete at the time the pullout tests are made

#### **Repairs at Resolute**

In the mid 90s concrete foundations at the Federal research base in Resolute were destroyed within two years of casting. An investigation revealed that the damage was caused by Thaumaside (Bickley et al 1994). Resolute is approximately 75° North, about 6 hours by jet from Montreal. A supply ship calls once a year. The nearest testing laboratory was thousands of kilometres away. The initial repairs were unsatisfactory and the contractor had to repeat them at his own expense. All the concrete making materials and plant had to be flown in.

The final repair of a hangar involved recasting 14 column bases which had to be supported by a substantial metal frame, of which only one was sent to site due to its weight. The schedule called for one base a day. By changing the mix and testing it with pullouts at an age of four hours it was possible to use the support frame twice a day. This reduced the casting time from 14 days to 7 days and resulted in considerable savings.

#### **Conclusions**

The experiences described in this paper confirm the utility and potential for safety and economy by the use of pullout testing. While the information above comes primarily from experience in Ontario reports on the extensive use of pullout testing worldwide come to the same conclusions.



## References

### Publications by Researchers

Skramtajev, B. G., 'Determining Concrete Strength for Control of Concrete in Structures', *ACI Proceedings*, vol. 34, Jan.-Feb. 1938, pp 285-303 American Concrete Institute, Detroit, USA.

Kierkegaard-Hansen, P., "LOK-strength", *Nordisk Betong*, nr. 3-4, 1975, Stockholm, Sweden.

Krenchel, H., "Lok-Strength Testing of Concrete", *Report No S/9*, Structural Research Laboratory, Technical University of Denmark, Copenhagen, 1970.

Malhotra, V. M., "Evaluation of the Pull-Out Test to Determine Strength of In-Situ Concrete", *Materials and Structures, Research and Testing, (RILEM, Paris)* V. 8, No. 43, Jan.-Feb. 1975, pp19-31.

### Publications by Author

"The Variability of Pullout Tests and In-Place Concrete Strength", *Concrete International*, April 1982, pp44-51.

"Concrete Optimization", *Concrete International*, June 1982.

"Trinity Square: Commentary on Concrete Test Data", *ASTM Cement, Concrete and Aggregates*, Volume 6, Number 1, Summer 1984.

"The Evaluation and Acceptance of Concrete Quality by In-Place Testing", *International Conference on In Situ/Non-Destructive Testing of Concrete*, Ottawa, Oct. 1984, ACI SP-82, pp. 95-110.

With Ryell, J. "Scotia Plaza: High Strength Concrete for Tall Buildings", *1<sup>st</sup> International Symposium on the Utilization of High Strength Concrete*, Stavanger, Norway, June 1987, proceedings, pp641-654.

"Pull-out Testing of Concrete", with H. Krenchel, *Nordic Concrete Research No. 6*, Dec. 1987, Oslo, pp. 155-168.

"Field Manual for Maturity and Pullout Testing on Highway Structures", *SHRP-C-376*, Strategic Highway research Program, National Research Council, Washington, DC, 1993

With Hemmings, R.T., Hooton, R.D. and Balinski, J., "Thaumasite Related Deterioration of Concrete Structures", *American Concrete Institute Proceedings, Concrete Technology, Past, Present and Future*, Special Publication SP 144, pp. 159-175, 1994.

With R.D. Hooton and K.C. Hover, "Preparation of a Performance-based Specification for Cast-in-place Concrete". *RMC Research Foundation*, January 2006. And "Guide to Specifying Concrete Performance", *RMC Research & Education Foundation*, March 2008.