

...FROM THE EUROPEAN CONCRETE BUILDING PROJECT



Introduction

The European Concrete Building Project is a joint initiative aimed at improving the performance of the concrete frame industry.

The principal partners in the world's most ambitious concrete research program are:

British Cement Association
Building Research Establishment Ltd
Construct – the Concrete Structures Group
Reinforced Concrete Council
Department of the Environment, Transport and the Regions

The program involves the construction of a series of full-sized concrete structures in the Large Building Test Facility at Cardington, where they are being subjected to comprehensive testing of the building process and of their performance.

With support from the DETR and the Engineering and Physical Sciences Research Council, the first of these buildings, a seven-story in-situ flat slab concrete frame, was completed in 1998. The results of investigations into all aspects of the concrete frame construction process are summarized in this series of Best Practice Guides.

These Guides are aimed at all those involved in the process of procurement, design and construction of in-situ concrete frames. They should stimulate fundamental change in this process in order to yield significant improvements in the cost, delivery time and the quality of these structures.

Early age strength assessment of concrete on site

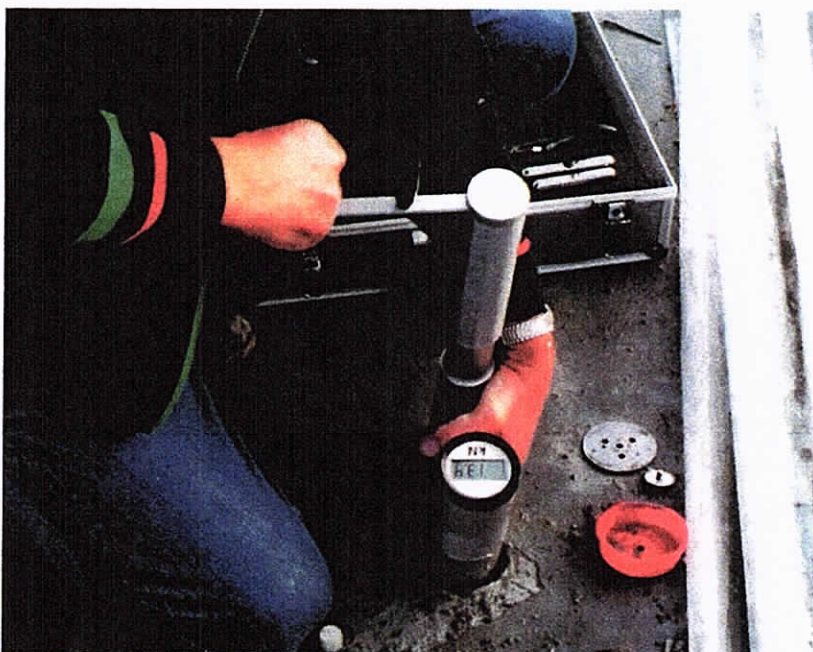

Figure 1: The Lok-test jack in position.

This Guide provides recommendations for determining the strength of concrete on site at early ages (less than three days)

Key messages

Knowledge of concrete strength at an early age:

- Allows significantly increased efficiency of in-situ concrete frame construction.
- Enables early striking of formwork and its economic re-use. This is further explained in a companion Best Practice Guide, Early striking for efficient flat slab construction.
- Enables early prestressing with safety.
- Can give an indication of long-term strength, enabling early confirmation of the quality of the concrete as placed.

Best practice

- Use pull-out inserts cast into the concrete to determine early age strength.
- Horizontally cast members (e.g. slabs) – locate inserts, using a floating cup, on the top surface of the slab near the end of the pour.
- Vertically cast members (e.g. walls, columns) – locate inserts on the formwork, with provision for early access before striking.

Recommended test method

The principle behind the test method is that the force required to pull an insert out of concrete can be correlated with the concrete's compressive strength.

The test equipment most commonly used in the UK at the current time is the Lok-test system. Load is applied through a manually operated jack (Figure 1) that screws into the stem of the insert. The jack bears against the concrete surface through a reaction ring, typically of 55 mm internal diameter. From the peak tensile force recorded by the jack, and by using an empirical correlation chart (Figure 2), the equivalent concrete cube strength can be estimated. Details of the actual correlation chart to be used, together with the appropriate confidence limits, are available from the manufacturer of the Lok-test equipment. (See below for address.)

Two main types of insert are used (Figures 3 and 4). For horizontally cast concrete there is a plastic buoyancy cup that floats on the top surface of the concrete, while for vertically cast concrete the insert is attached directly to the formwork. The floating cup inserts are particularly easy to use since they do not require any pre-planning, but care must be taken to avoid the reinforcement. They are placed by the hand and it is not essential that they remain perfectly vertical.

One key feature of this method is that small changes in compressive strength are easily detected. Also concrete variables such as aggregate type do not significantly affect the correlation.

In the absence of the more specific tests for correlation, the manufacturer's recommended strength correlation for these pull-out tests may be relied upon. When used in combination with the suggested locations for sampling the concrete and appropriate confidence limits, this will give a lower bound strength.

Site planning and practical issues

Check that localized test damage to the concrete surface finish will be acceptable.

Position inserts 50 mm clear of reinforcement.

Use regularly calibrated equipment.

Use a trained operator.

Base strength assessment on an average of at least four results.

In general, due to relative differences in curing and compaction, concrete at the top of a pour is less strong than that at the bottom, so strengths derived from testing the top surface may be considered to be conservative. If it is necessary to test vertically-cast members, access to the test concrete will need to be provided, e.g. by providing small removable panels in the formwork.

Background

Most concrete delivered to site is covered by quality schemes. However, many users need to have specific data on the strength of the concrete as placed in their structure, e.g. for early striking of formwork or early prestressing for safety. This has led to significant benefits in terms of process efficiency and overall speed of construction.

The disadvantages of cube testing for early-age strength assessment are:

- Generally, the results of testing come too late to allow economical remedial action to be taken should a problem occur.
- Despite best intentions, the samples are not necessarily representative of the concrete in situ.
- The making, storing, transporting, testing and cleaning of cubes and cube moulds is a time consuming and non-productive process, and will usually be impractical for very early age strength measurements.

These shortcomings are eliminated if measurements of concrete strength are made in situ. The determination of formwork striking time or prestressing time is a two-stage process. The first stage is to calculate the strength required for the concrete to resist the dead load of the structure plus the estimated construction load. For formwork striking this is further explained in the companion Guide, Early striking for efficient flat slab construction. The second stage is to determine a lower bound estimate of the concrete's strength as recommended in this Guide.

Techniques for assessing the in-situ strength of concrete have improved greatly over the past 20 years and the in-situ concrete building at Cardington provided an ideal opportunity to assess what could be achieved using

The Lok-test equipment can be obtained from the U.S. manufacturer:
Germann Instruments, Inc.
Tel. (847) 329-9999
Fax. (847) 329-8888
e-mail: germann@interaccess.com
Web site: <http://www.germann.org>

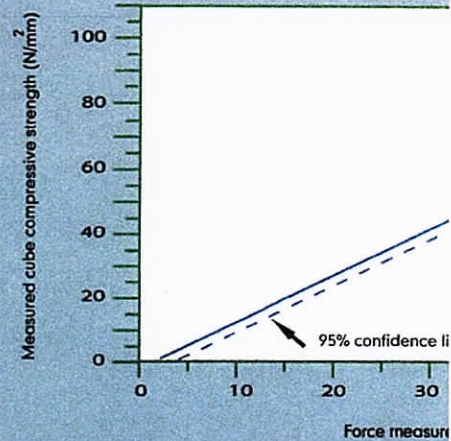

Figure 2: Illustrative correlation chart showing the Lok-test and by convention

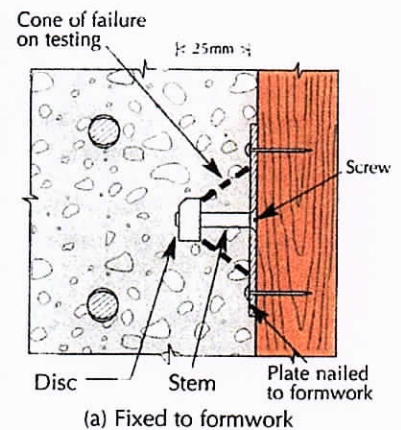

Figure 3: Lok-test inserts

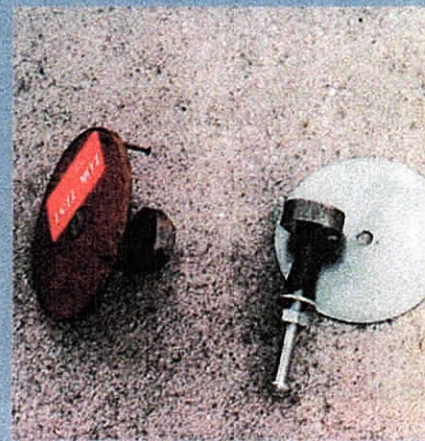
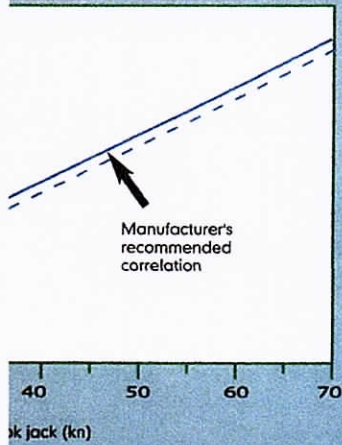
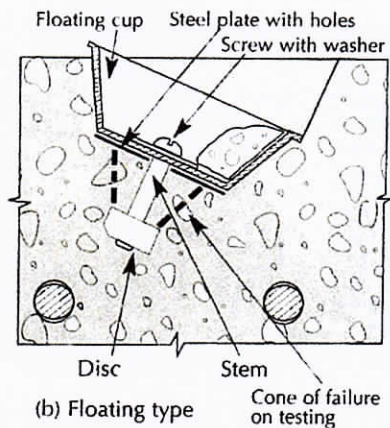

Figure 4: Lok-test inserts for form work



between strengths determined by Lok jack testing and cube testing.



(b) Floating type



and floating cup (right)

the best possible practices. A structured program of tests conducted by Liverpool University and Queen's University of Belfast enabled the relative merits of different techniques to be effectively assessed and compared. It should be stressed that many of these techniques are not new and are dealt with extensively in relevant parts of BS 1881 (1).

Details of results from Cardington

The results are summarized below. Further information about the work carried out on the in-situ concrete building at Cardington and background references can be found in the main research report.

- For the Lok-tests the combined correlation for all concretes was found to be very close to the manufacturer's correlation (Figure 5). This is particularly encouraging given the very diverse range of different strengths, cement types and workabilities (see Best Practice Guide, Concreting for improved speed and efficiency). Each of the 30 points plotted on the graph is an average of four test results.
- The correlation curves for the Lok-test were found to be applicable to the Capo test (see Table 1).
- The value of in-situ tests such as the Lok-test was clearly demonstrated as a means of verifying that the required strength for early striking (as early as 19 hours after placing the final concrete in a slab) had indeed been achieved.
- Where minimal damage to the surface of the finished concrete is acceptable, Lok-tests carried out in sufficient number and at the

appropriate locations can replace information from temperature matched cubes. Air-cured cubes will tend to give a lower bound estimate of the in-situ strength (i.e. the results are conservative). This means that they will not allow the full benefits of early striking to be derived, particularly in cold weather conditions.

In-situ tests such as the Lok-test can be carried out quickly and easily as required, whereas there are logistical difficulties in transporting cubes to a testing house and having staff available at short notice to test the specimens.

A single correlation curve could not be derived for the Limpet pull-off test (as opposed to the pull-out tests recommended) or for maturity measurements.

28 day in-situ concrete compressive strengths could be predicted from three day Lok-test results with a reasonable degree of accuracy. This finding should, however, be treated with caution since it will depend on the temperature history of the concrete up to three days after pouring and subsequently.

Acceptance of concrete and appropriate concrete quality control procedures need to be viewed in the context of the type of concrete specified and emerging British and European standards. These are moving towards avoiding the necessity for site testing. For the foreseeable future, formal compliance is likely to continue to be based on cube or cylinder strength measurements at 28 days.

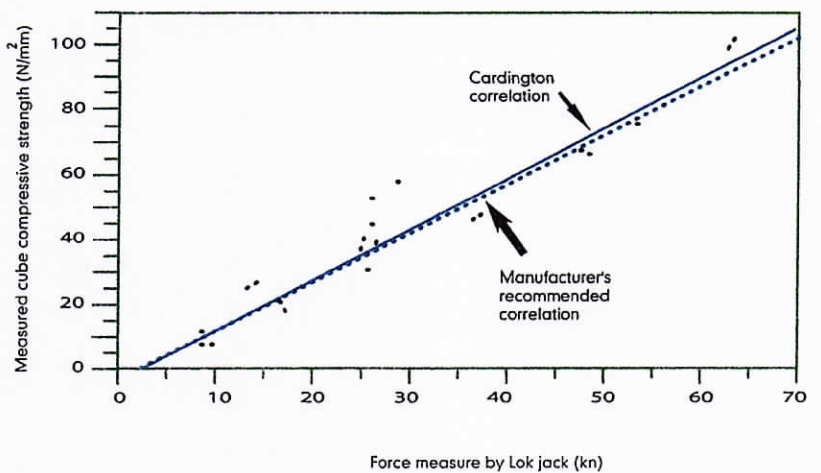

Figure 5: Correlation of Lok-test and cube tests carried out at Cardington.

BEST PRACTICE GUIDES FOR IN-SITU CONCRETE FRAME BUILDINGS

Comparison of test methods

The use of pull-out tests involving pre-planned inserts is the method recommended in this Guide. However, there may be situations where such testing is not appropriate, e.g. where special finishes are used, where the planned inserts have not been installed, or where increased

confidence is required from using a range of techniques. An outline description of available test methods is given in Table 1. Whatever techniques are employed, it is important that an attempt is made to determine a **lower** bound estimate of the concrete's strength.

Table 1: Comparison of test methods

Technique	Description	Advantages	Disadvantages
Lok-tests	Pull-out test involving pre-planned inserts either fixed to formwork or floating on top surface.	Quick, inexpensive, provide good correlation. Small changes in strength can be detected. Correlation is not mix specific.	Some preplanning needed. Some local damage.
Jack tests	Pull-out test involving drilling of concrete after hardening. Same jack and correlation curve used as for Lok-test.	Less preplanning required, inexpensive and provide good correlation. Correlation is not mix specific. Useful for supplementary tests.	Slower than Lok-test. Some local damage. Surface preparation may be needed.
Maturity measurement	Direct measurement of temperature-time history of concrete.	Relatively inexpensive.	Correlation with strength is mix specific.
Cube testing* (Air-cured cubes)	Compressive testing of cubes made on site in accordance with BS 1881 and stored adjacent to the structure in ambient conditions.	Less expensive than temperature-matched cubes. Provides lower bound value.	Costs of making, transporting, testing etc. Not testing concrete actually in the structure.
Temperature matched cubes	Compressive testing of cubes made on site and stored under controlled conditions in accordance with BS 1881: Part 130: 1996.	Provides accurate results	Relatively expensive. Disadvantages as for air-cured plus extra equipment costs. Impracticality of use on site.
Sheet pull-off	Pulling off a metal disc together with a surface layer of concrete bonded to the disc.	Inexpensive to perform. No pre-planning required. Superficial damage only.	Correlation is mix specific. Time needed for bonding to surface. Surface preparation needed. Poor correlation between pull-off force and concrete strength.

* Water-cured cubes should not be used for early age strength assessment, because the curing environment is not related to that of the concrete in the structure.

This Best Practice Guide is based on research report, Early age acceptance of concrete (*Improved quality management*), by J.J. Bungey, A.E. Long, M.N. Soutsos and G.D. Henderson. BRE Report 387, published by CRC Ltd.

References

1. BSI. Testing concrete. London BS 1881. Parts 5-209, 1970-1998.

Best Practice Guides in this series

- Improving concrete frame construction
 - Concreting for improved speed and efficiency
 - Early age strength assessment of concrete on site
 - Improving rebar information and supply
 - Early striking for efficient flat slab construction
 - Rationalization of flat slab reinforcement
- Further Guides are planned

Research partners for this Guide

Liverpool University
The Queen's University of Belfast
Building Research Establishment Ltd
RMC Readymix Limited

97.503

First published 2000

ISBN 0 7210 1554 9

Price group A

© BCA, BRE Ltd, Construct, RCC, DETR.

Published by the British Cement Association on behalf of the project partners.

British Cement Association
Century House
Telford Avenue
Crowthorne, Berkshire RG45 6YS
www.bca.org.uk

For further copies of the Best Practice Guides ring the Concrete Bookshop on 01344 725704.

All advice or information from the British Cement Association is intended for those who will evaluate the significance and limitations of its contents and take responsibility for its use and application. No liability (including that for negligence) for any loss resulting from such advice or information is accepted. Readers should note that all BCA publications are subject to revision from time to time and should therefore ensure that they are in possession of the latest version.